

Diamond Cabinet Slant Top

Users Manual

Revision 1.0

1 Table of Contents

1.1 Sections

1	Table of Contents	2
1.1	Sections.....	2
1.2	List of Figures.....	3
1.3	List of Tables.....	3
2	Revision History.....	5
3	Overview	6
3.1	Dimensions	6
3.2	Operating Elements	6
3.3	Power up.....	7
3.4	Safety precautions.....	7
3.4.1	Static sensitive parts	8
3.4.2	Power off	8
3.4.3	Cabinet ventilation.....	8
3.4.4	Liquids	8
3.4.5	Uncommon behavior	8
3.4.6	Wires.....	8
3.4.7	Environment	8
4	Power supply	9
4.1	Position in machine	9
4.2	Removal.....	9
4.3	Characteristics	10
4.4	Connectors	10
4.4.1	AC Output Connector.....	10
4.4.2	DC Output Connector.....	10
4.4.3	Remote Switch Connector.....	10
5	Coin Acceptor.....	11
5.1	Function.....	11
5.2	Accepted coins.....	11
5.3	Error Handling.....	11
5.4	Replacement	11
5.5	Connector	12
6	Coin Hopper	13
6.1	Function.....	13
6.2	Payout coins.....	13
6.3	Error Handling.....	13
6.4	Replacement	13
6.5	Connector	14
6.6	Exploded view	15
7	Bill Acceptor	16
7.1	Function.....	16
7.2	Accepted bills	16
7.3	Adjustment and troubleshooting.....	16
7.4	Error handling.....	16
7.4.1	Cleaning.....	16

7.4.2	Bill is jammed in Acceptor.....	17
7.4.3	Bill is jammed near the acceptor's entrance	18
7.5	Connector	19
8	Hardware meters.....	20
8.1	Position in machine	20
8.2	Function.....	20
8.3	Troubleshooting.....	20
8.4	Exchange of the meters.....	20
9	Monitors	22
9.1	Position in machine	22
9.2	Function.....	22
9.3	Troubleshooting.....	23
9.4	Exchange of the monitors	23
10	Harness	24

1.2 List of Figures

Figure 1:	Machine dimensions	6
Figure 2:	Machine Operating Elements.....	7
Figure 7:	Coin Acceptor bracket position	11
Figure 8:	Removal of the coin acceptor.....	12
Figure 9:	Coin Acceptor Connector	12
Figure 10:	Coin Tray Remove Direction.....	13
Figure 11:	Coin Hopper Remove Direction	14
Figure 12:	Coin Hopper Connector	14
Figure 13:	Coin Hopper Exploded View.....	15
Figure 14:	Bill Acceptor Cleaning.....	17
Figure 15:	Removing jammed bill from the Bill Acceptor Stacker	18
Figure 16:	Removing jammed bill from the Bill Acceptor entrance.....	18
Figure 18:	Hardware Meters Position in Machine.....	20
Figure 19:	Exchange on the Hardware Meters Circuit Board	21
Figure 20:	Monitors Position in Machine.....	22
Figure 21:	Monitors Exchange	23
Figure 22:	Audio Connector	24
Figure 23:	JCM UBA10 Connector.....	24
Figure 24:	Buttons and Lamps Connector 1.....	24
Figure 25:	Buttons and Lamps Connector 2.....	25
Figure 26:	Coin Acceptor Connector	25
Figure 27:	Coin Hopper Connector	26
Figure 28:	iButton Connector.....	26
Figure 29:	Key and Door Switch Connector	26
Figure 30:	Hardware Meters Connector	27
Figure 31:	Power Connector.....	27
Figure 32:	Tower Light Connector.....	27

1.3 List of Tables

Table 1:	DC Output Connector Pin Layout.....	10
----------	-------------------------------------	----



Table 2: Accepted coin table	11
Table 3: Coin Acceptor Connector Pin Layout	12
Table 4: Payout coin table	13
Table 5: Coin Hopper Connector Pin Layout	14
Table 6: Accepted bill table.....	16
Table 7: Bill Acceptor Connector Pin Layout.....	19

2 Revision History

Version	Date	Author	Description
1.0	2010.03.10	Aleksej Geseltin	Initial document release
			-
			-

3 Overview

3.1 Dimensions

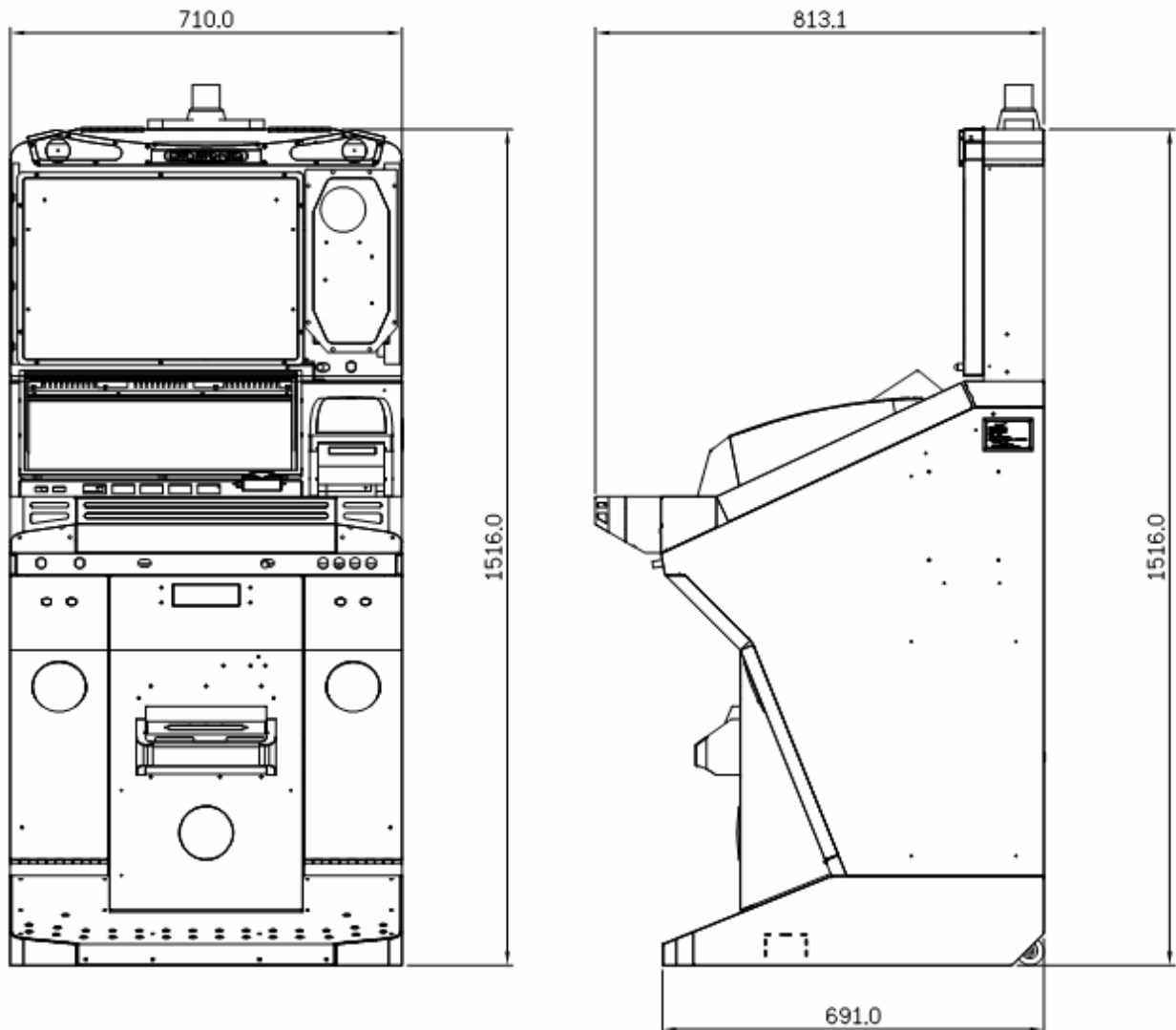

Figure 1: Machine dimensions

3.2 Operating Elements

1. Coin entry
2. Bill entry
3. I-Button key (optional)
4. Main door lock
5. Coin tray

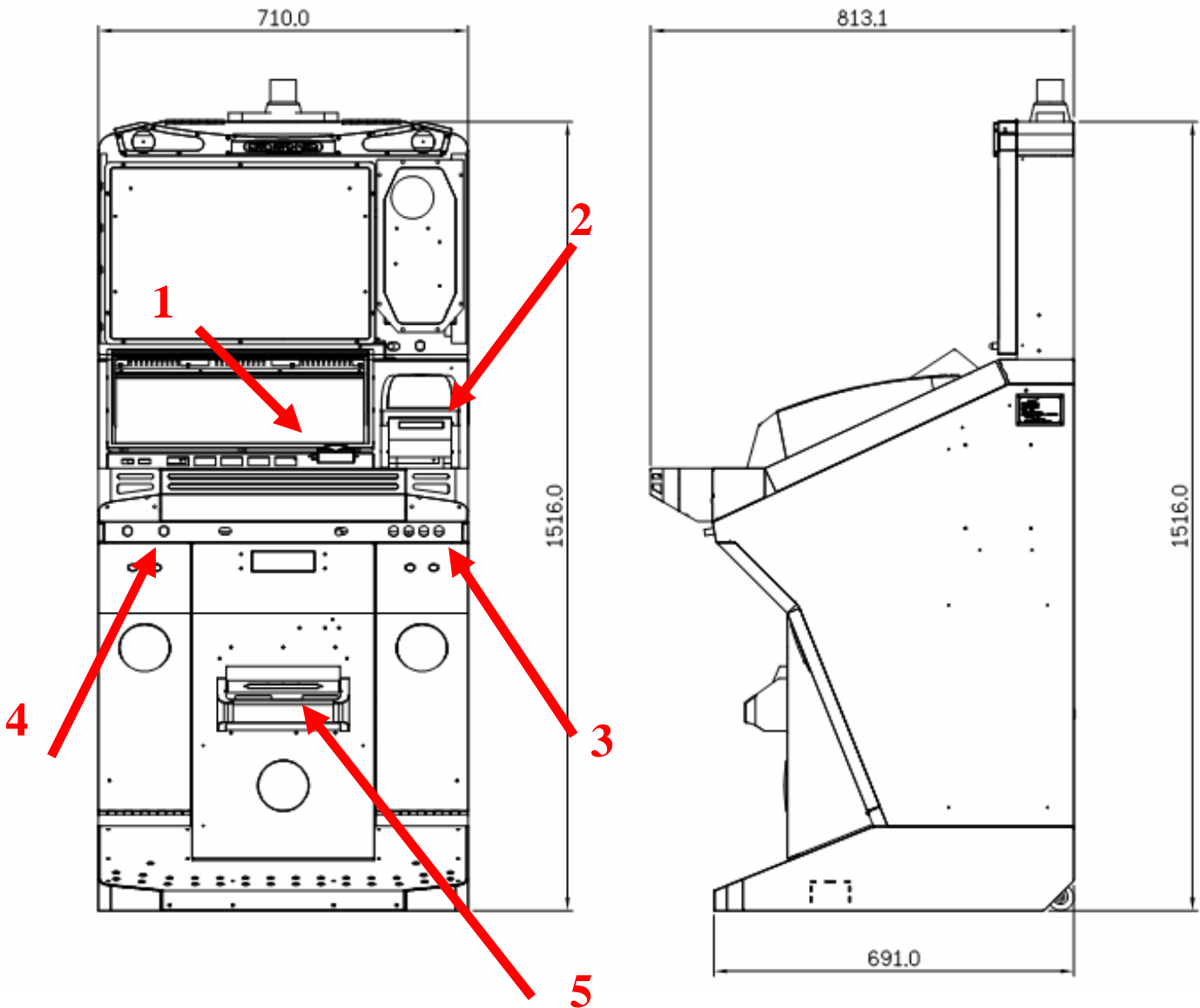

Figure 2: Machine Operating Elements

3.3 Power up

Before start check the line voltage and grounding. Machine is designed to operate at 100-120V/200-240V, 50-60Hz.

AC power outlet to which machine is connected should be easily accessed in case of emergency.

3.4 Safety precautions

This section is provided to avoid damage to the machine and minimize damage and chances of electric shock to maintenance personnel and users.

3.4.1 Static sensitive parts

Machine contains static-sensitive components, which could be damaged by electric discharges. Before maintaining inner components of the machine always touch ground straps inside the machine to neutralize electric charges.

3.4.2 Power off

In case of emergency power off the machine!

The machine will be completely powered off only when the AC plug is removed from the outlet. If the machine is connected with the uninterruptible power supply, be sure to switch it off.

WARNING: Unplugging the machine with wet hands or in wet environment can result in electric shock.

3.4.3 Cabinet ventilation

Do not block or insert any objects into the ventilation holes. This may result in machine overheating or could result in risk of fire or electric shock.

Provide adequate space between machine and other objects, to allow normal ventilation conditions.

3.4.4 Liquids

Avoid spilling any kind of liquids on the machine. This may result in risk of fire or electric shock. In case of an accident, unplug the machine immediately and contact the qualified technical staff.

3.4.5 Uncommon behavior

If there are unusual sounds, lights or smells coming out of the machine, power off the machine completely and contact the qualified technical staff. Failure of doing so may result in risk of fire.

3.4.6 Wires

Make sure that all the wires inside and outside of the machine are not damaged, squeezed or stretched. Also check the wire near the AC plug is not frayed.

Damaged wires can cause short circuit or fire risks.

3.4.7 Environment

Machine is suitable for indoor use only!

Do not expose the machine under any circumstances to wet environments or temperatures greater than 50°C.

After transportation or storage in cold environments do not power up machine immediately, wait for machine to reach normal operating temperature.

The recommended operating temperature is between 10°C and 35°C and relative humidity of 30% to 80% (non-condensing).

Do not install machine near heaters or other electronic devices that produce a lot of heat or dust. Failure of doing so can result in risk of machine malfunction, overheating or fire.

4 Power supply

4.1 Position in machine

The power supply is located under the Logic box (as shown on picture).

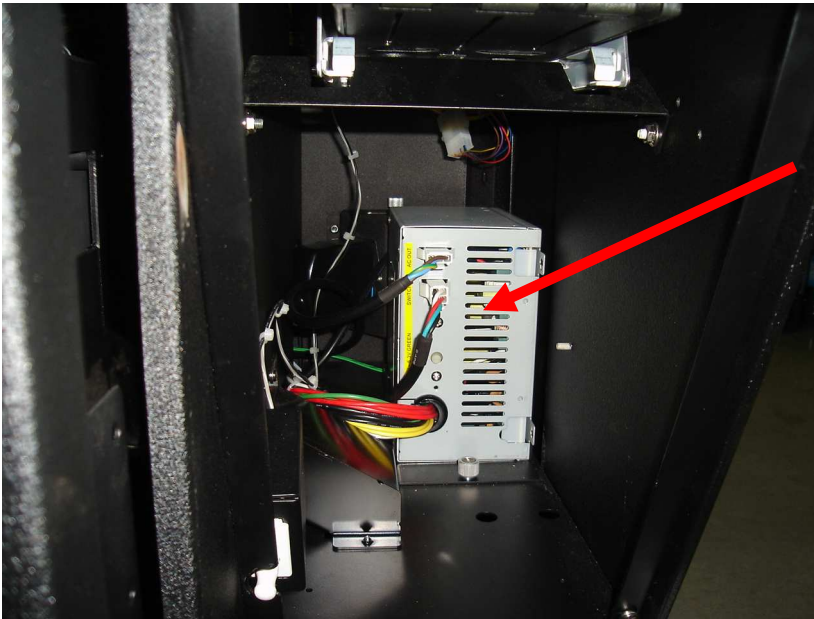

4.2 Removal

To remove the power supply, disconnect all the wiring and unscrew one screws that hold the power supply in place (shown with red arrows).

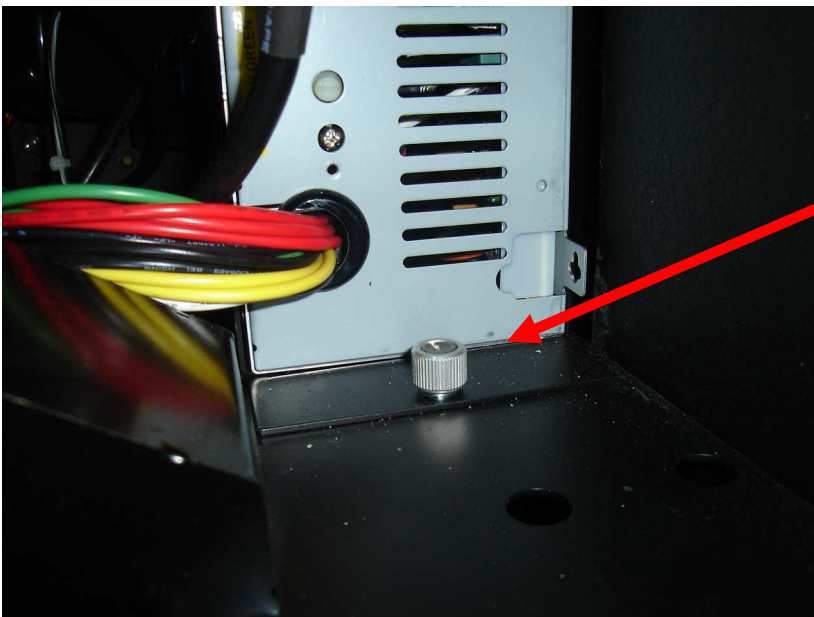

4.3 Characteristics

Type	WEI-YA
Model	P2051B
Input	100-120/200-240 V
Output	+5V:8A
Output	+12V:6A
Output	-12V:1A
Output	+24V:6A
Output watt	260 W

4.4 Connectors

4.4.1 AC Output Connector

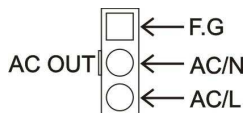

Figure 3: AC Output Connector

4.4.2 DC Output Connector

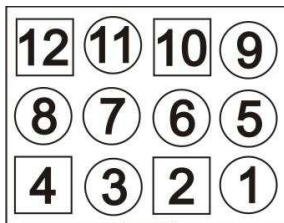

Figure 4: DC Output Connector

Pin No.	Color	Description
4, 8, 12	RED	+5V
5, 9	YELLOW	+12V
7, 11	GREEN	+24V
1	WHITE	-12V
2, 3, 6, 10	BLACK	GND

Table 1: DC Output Connector Pin Layout

4.4.3 Remote Switch Connector

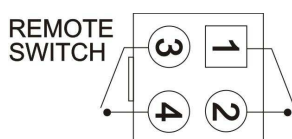

Figure 5: Remote Switch Connector

5 Coin Acceptor

5.1 Function

Type **NRI G-13** or compatible coin acceptor with up to 6 pre-programmed coin channels

The coin diverter is mounted underneath the coin acceptor and sorts the coins depending on the hopper fill level either to the hopper or directly to the cash box.

5.2 Accepted coins

Machine can accept following coins:

Country	Coin value
Latvia	1 LVL

Table 2: Accepted coin table

5.3 Error Handling

1. Unplug the machine and open the main door;
2. Check that the coin acceptor is positioned correctly, remove any jammed coins;
3. Ensure that the coin acceptor cable is connected properly to the device;
4. Check if coin sorter can freely move for one position to another.

5.4 Replacement

If coin acceptor can not be fixed in-place, the complete device should be replaced.

1. Unplug the machine and open the main door;
2. Loosen white plastic brackets;
3. Tilt the upper part of coin acceptor first, and then remove coin acceptor from the bracket;
4. Unplug the cable;
5. Repeat steps above in the reverse order;

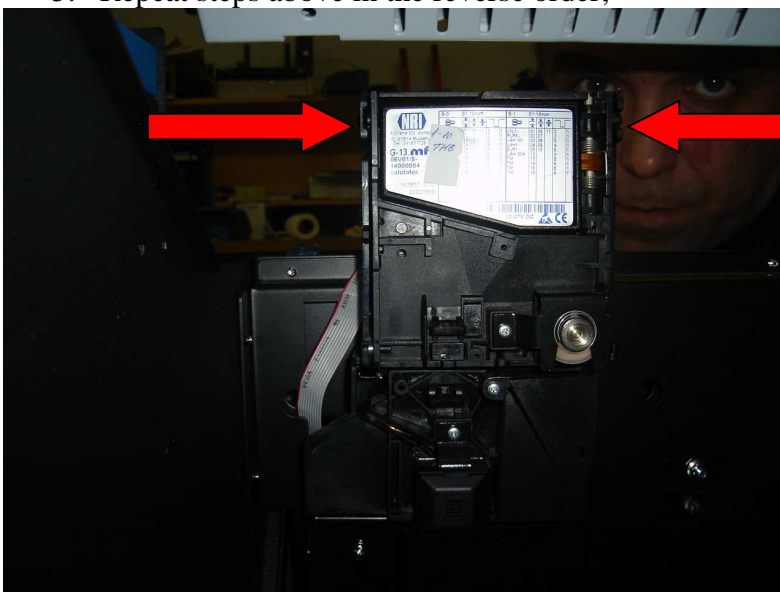

Figure 3: Coin Acceptor bracket position

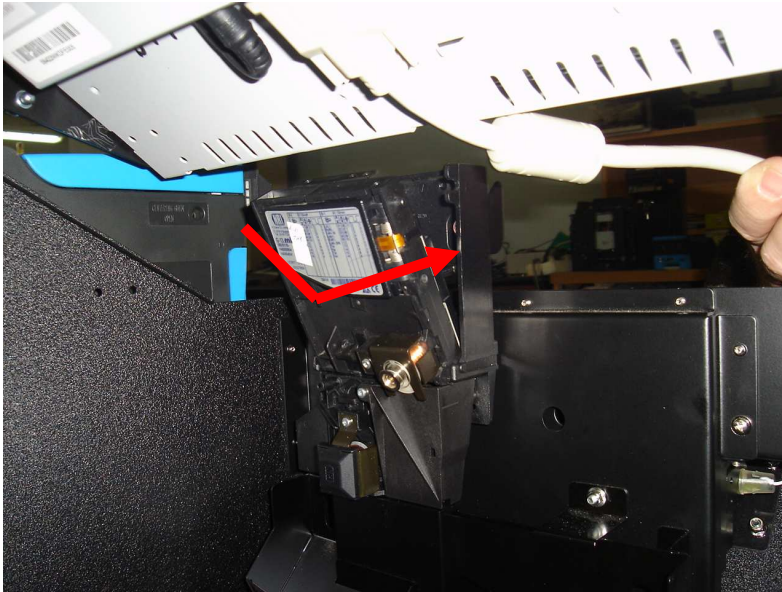

Figure 4: Removal of the coin acceptor

5.5 Connector

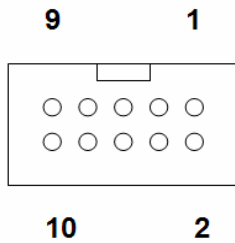

Figure 5: Coin Acceptor Connector

Pin No.	Description	Potential
1	GND	Low
2	+12V DC	High
3	Coin E	Active low
4	Coin F	Active low
5	Return	Active low
6	Common inhibit	Active high
7	Coin A	Active low
8	Coin B	Active low
9	Coin C	Active low
10	Coin D	Active low

Table 3: Coin Acceptor Connector Pin Layout

6 Coin Hopper

6.1 Function

Type Money Controls Universal Hopper MK IV
Suzo Evolution Hopper EV01000

WARNING: Machine should be power off before removing or installing coin hopper!

6.2 Payout coins

Machine can pay out following coins:

Country	Coin value
Latvia	1 LVL

Table 4: Payout coin table

6.3 Error Handling

1. Check the correct mounting of the hopper;
2. Check the plug fitting;
3. Remove jammed coins if such exist
4. Clean the hopper from dirt and dust

6.4 Replacement

1. Unplug the machine and open the door forward
2. Unscrew one screws
3. Remove the Hopper back.

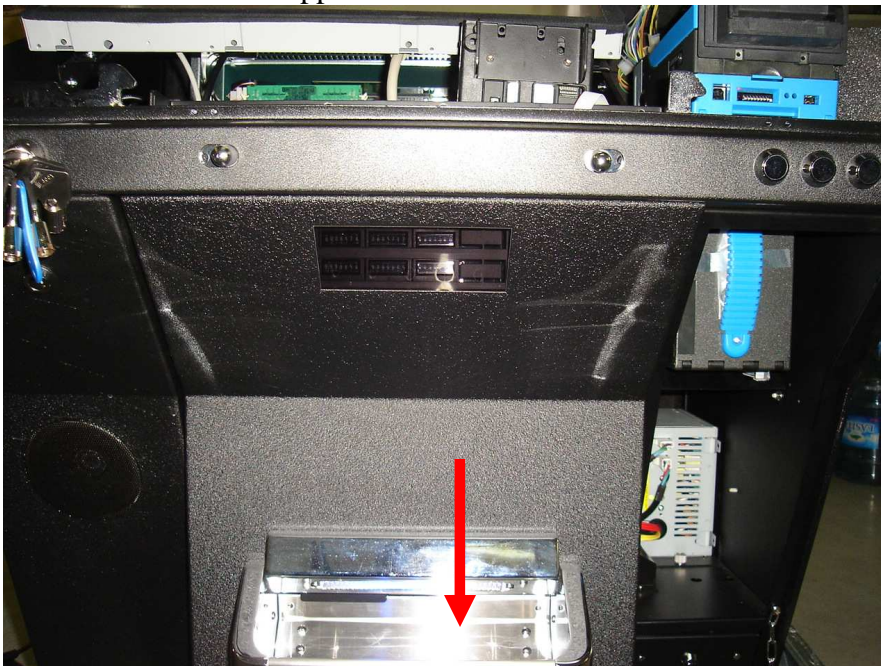

Figure 6: Coin Tray Remove Direction

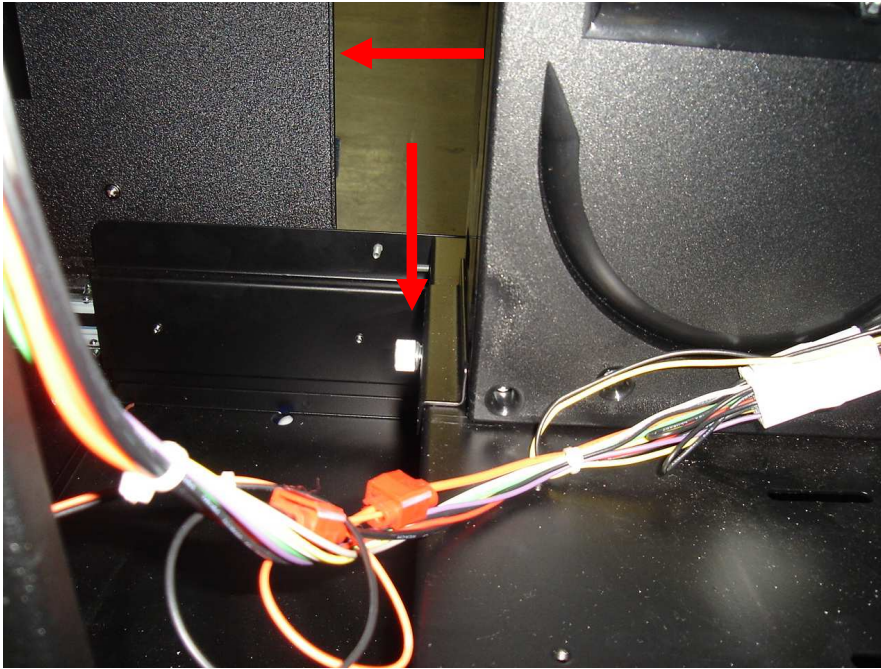

Figure 7: Coin Hopper Remove Direction

6.5 Connector

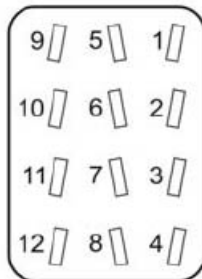

Figure 8: Coin Hopper Connector

Pin No.	Description
1	Motor supply 0 volt
2	Logic 0 volt
3	uP Sensor Output
4	IN1
5	Security output
6	High level sense output
7	Low level sense output
8	IN2
9	Motor supply +24V
10	Logic supply
11	Raw Sensor Output
12	IN3

Table 5: Coin Hopper Connector Pin Layout

6.6 Exploded view

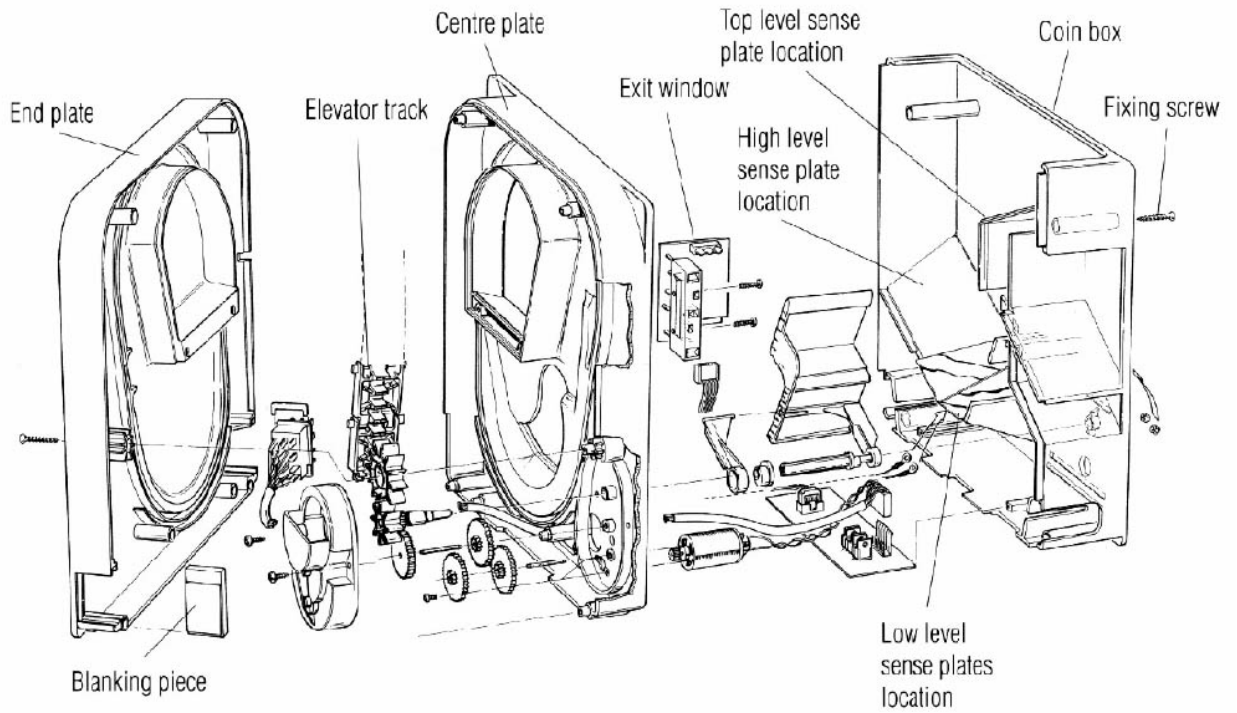

Figure 9: Coin Hopper Exploded View

7 Bill Acceptor

7.1 Function

Type JCM UBA/WBA

The Bill validator accepts the bank notes in all 4 directions. By changing software in flash memory any country settings can be adjusted.

7.2 Accepted bills

Machine can accept and handle following banknotes

Country	Bill value
Latvia	5 LVL
	10 LVL
	20 LVL
	50 LVL
	100 LVL

Table 6: Accepted bill table

7.3 Adjustment and troubleshooting

Adjust voltage with potentiometer (see picture “removal of power supply”):

We suggest to do final adjustment of the +12V when machine is installed at final destination. Check +12V with Voltmeter at the output of the power supply and adjust by turning the potentiometer.

In case of a short circuit in the machine the power supply switches off automatically.

Switch machine back on after repair of the short circuit. In most cases the power supply will work properly again (red LED lit).

7.4 Error handling

7.4.1 Cleaning

To clean the lenses, use a lint-free cloth and mild nonabrasive detergent such as liquid dish soap mixed with water.

1. Pull the tabs on both sides of the acceptor forwarded to open the acceptor's head;
2. Open the acceptor head front and rear covers to clean bill path, rollers and belts.

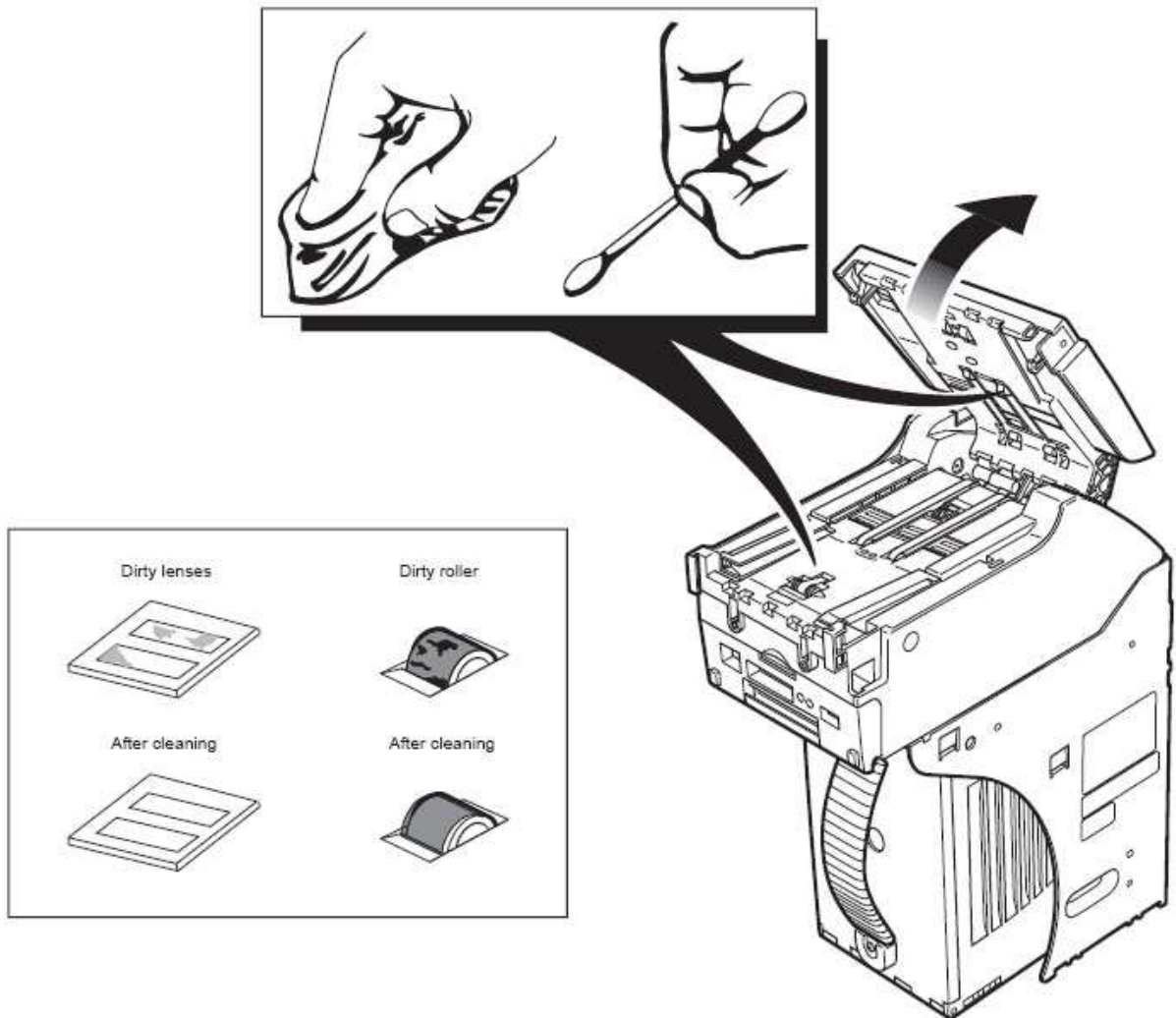

Figure 10: Bill Acceptor Cleaning

7.4.2 Bill is jammed in Acceptor

When a bill is jammed near the entrance of the stacker box, unlock the box and pull it out to remove the jammed bill.

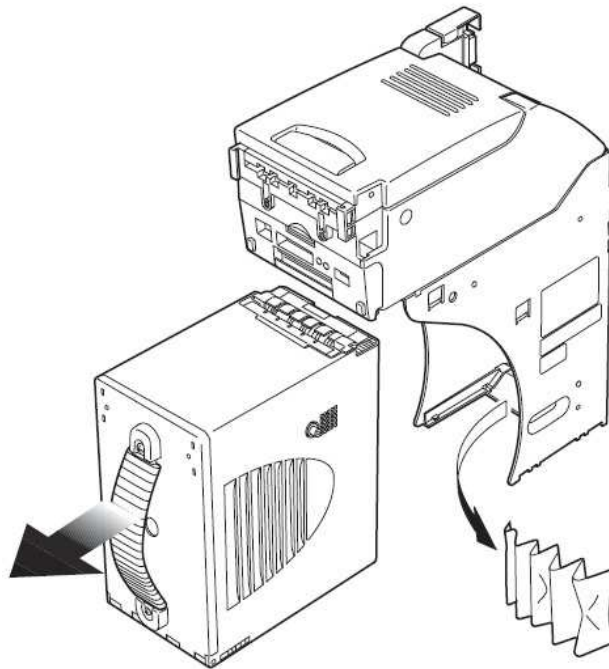

Figure 11: Removing jammed bill from the Bill Acceptor Stacker

7.4.3 Bill is jammed near the acceptor's entrance

When a bill is jammed near the acceptor's entrance, pull the tabs on the top of the acceptor to open the cover of acceptor's unit. Remove the jammed bill.

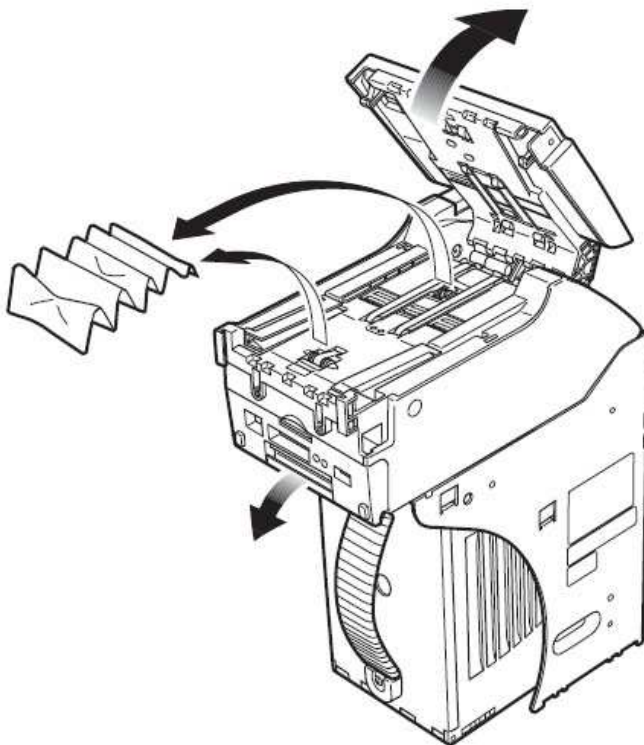

Figure 12: Removing jammed bill from the Bill Acceptor entrance

7.5 Connector

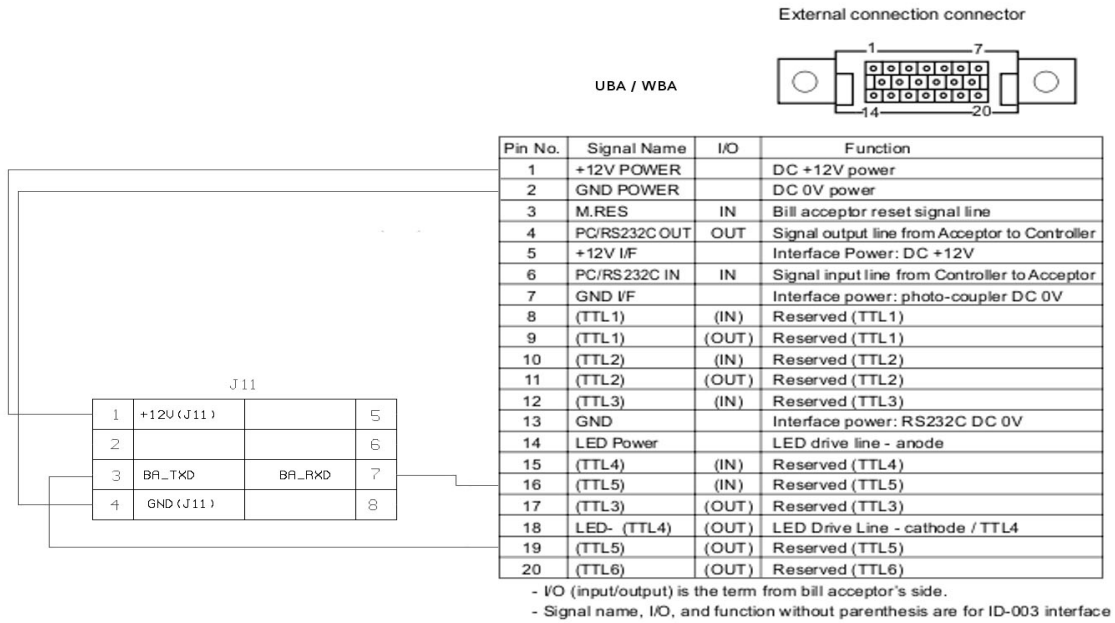

Table 7: Bill Acceptor Connector Pin Layout

8 Hardware meters

8.1 Position in machine

Hardware meters are mounted on the main door above coin tray.



Figure 13: Hardware Meters Position in Machine

8.2 Function

1. CREDITS WAGERED
2. CREDITS WON
3. GAMES PLAYED
4. BILL IN
5. COIN DROP
6. HANDPAY

8.3 Troubleshooting

1. Check the connectors of the meter unit.
2. If an error message is triggered by a malfunction or non-activation of individual meter, the device must be removed from the operation and the meters circuit board must be exchanged.

8.4 Exchange of the meters

If any defects cannot be repaired, the defective meter has to be exchanged.

1. Unplug the machine and open the main door;
2. Unscrew screws as shown on picture;
3. Remove meters circuit board;

4. Unplug cable from the meters circuit board;

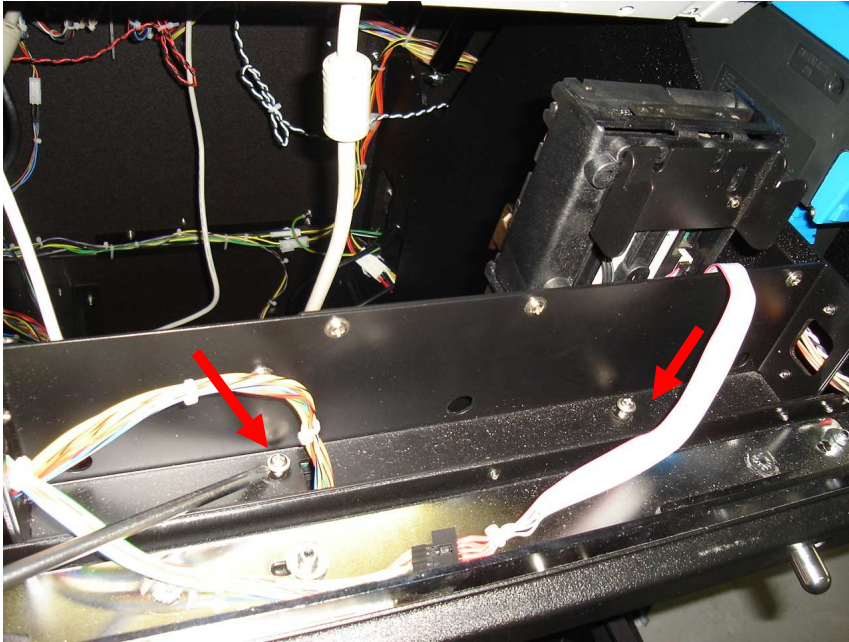

Figure 14: Exchange on the Hardware Meters Circuit Board

9 Monitors

9.1 Position in machine

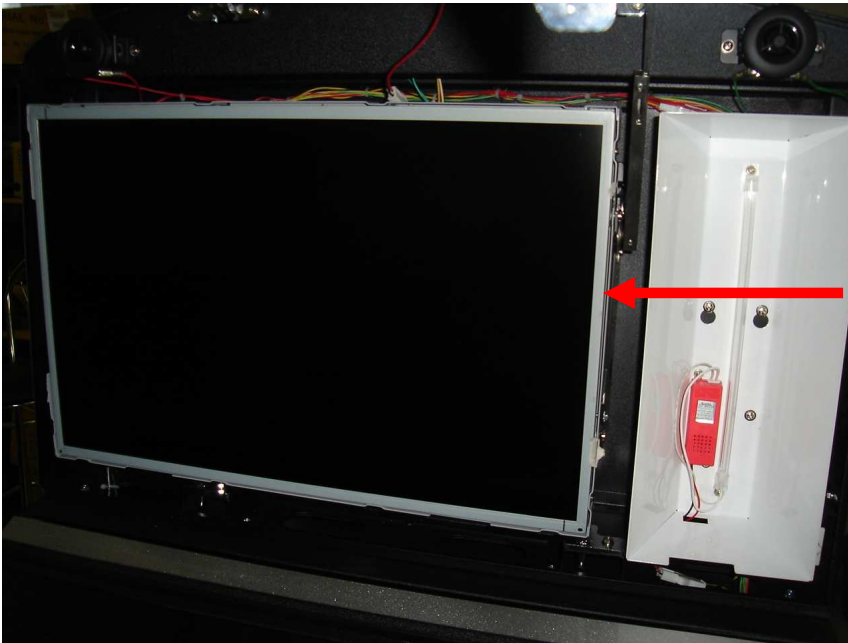
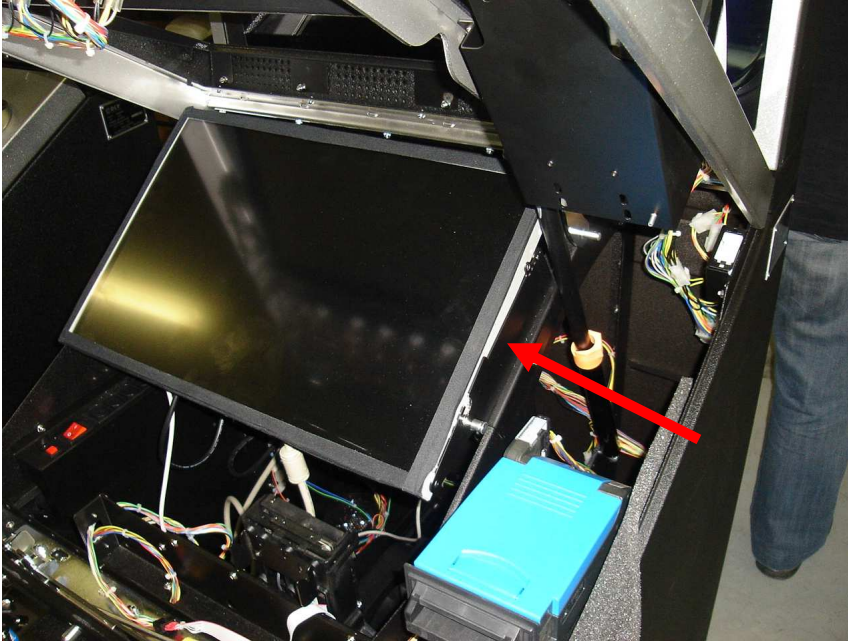

Figure 15: Monitors Position in Machine

9.2 Function

The monitors show the game play, the error messages and the audit system.

9.3 Troubleshooting

Check if the monitors and the connectors of the cables are fixed correctly in their mounting.

9.4 Exchange of the monitors

If any defects cannot be repaired, the defective monitor has to be exchanged.

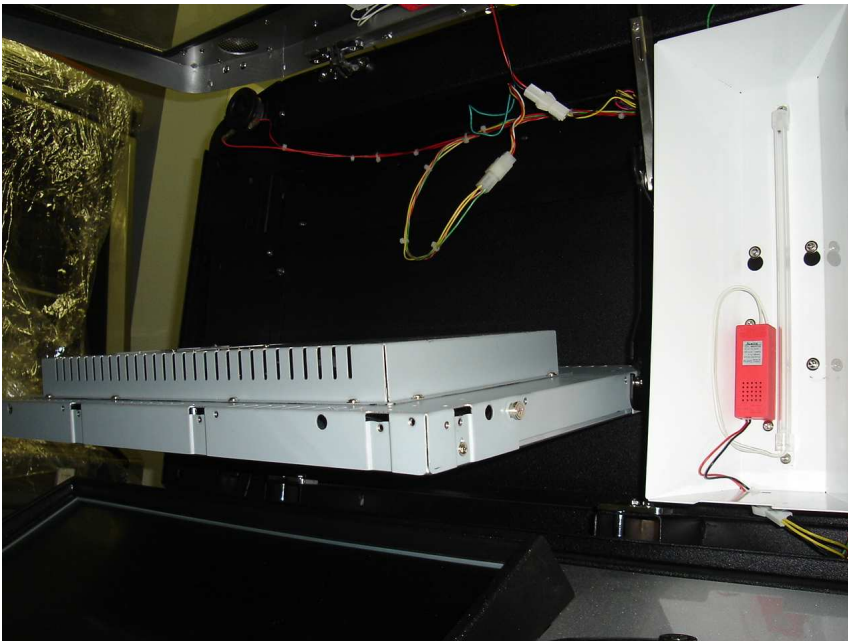

Figure 16: Monitors Exchange

10 Harness

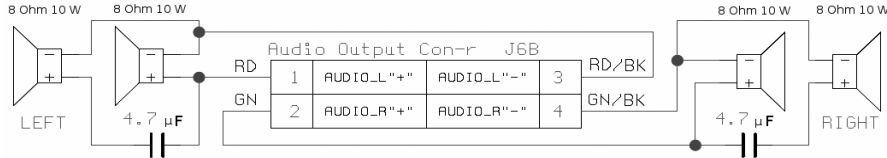

Figure 17: Audio Connector

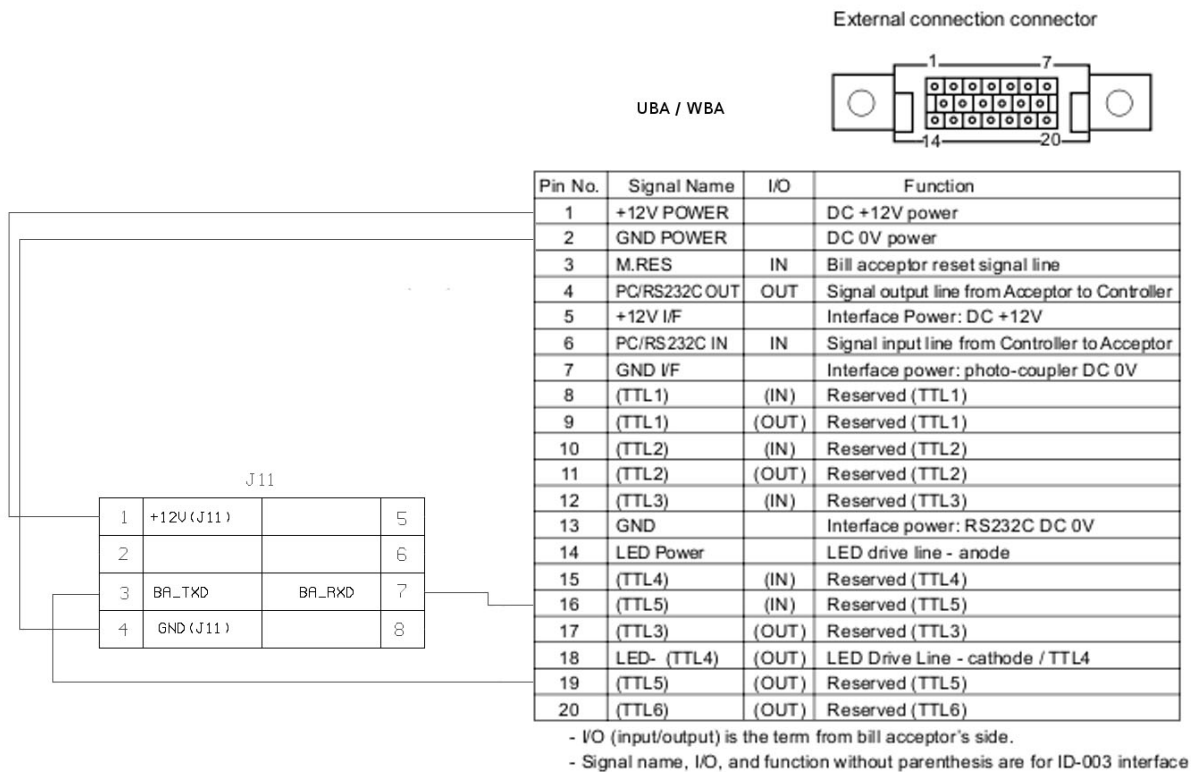

Figure 18: JCM UBA10 Connector

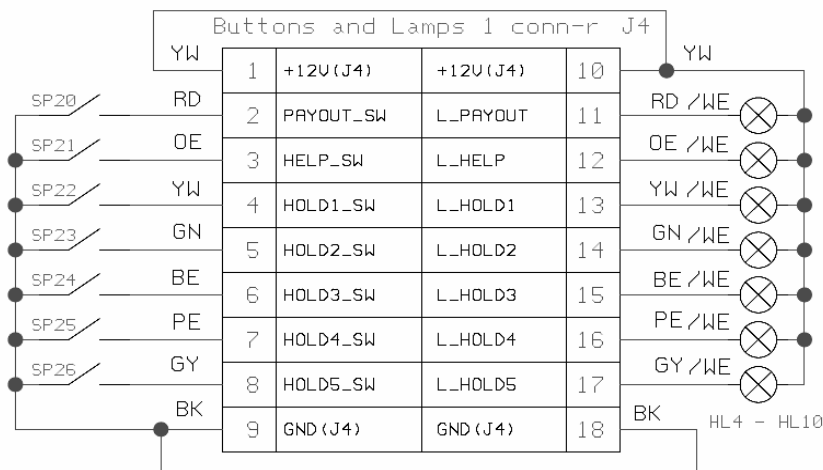

Figure 19: Buttons and Lamps Connector 1

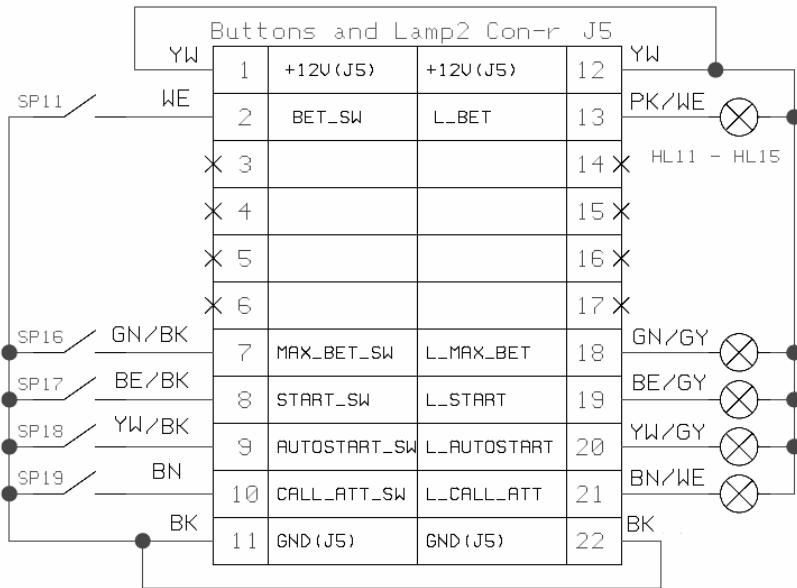

Figure 20: Buttons and Lamps Connector 2

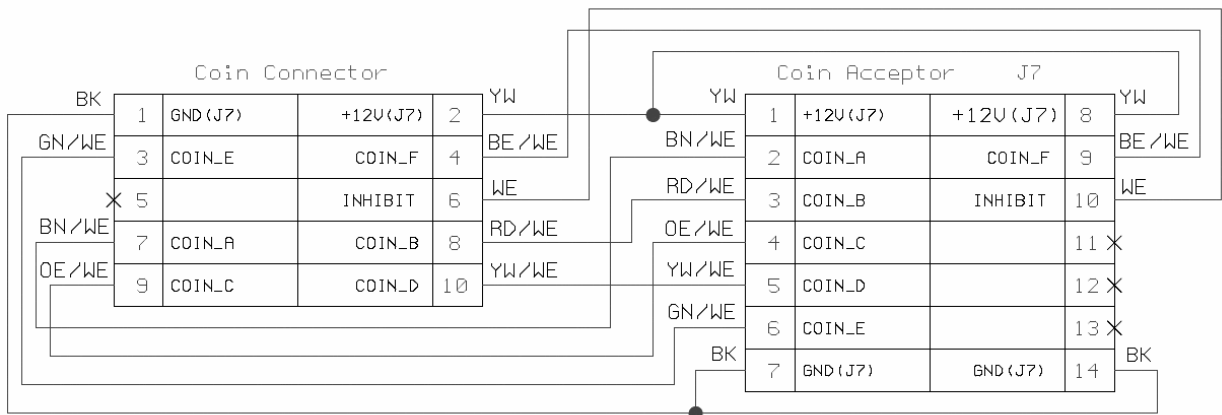

Figure 21: Coin Acceptor Connector

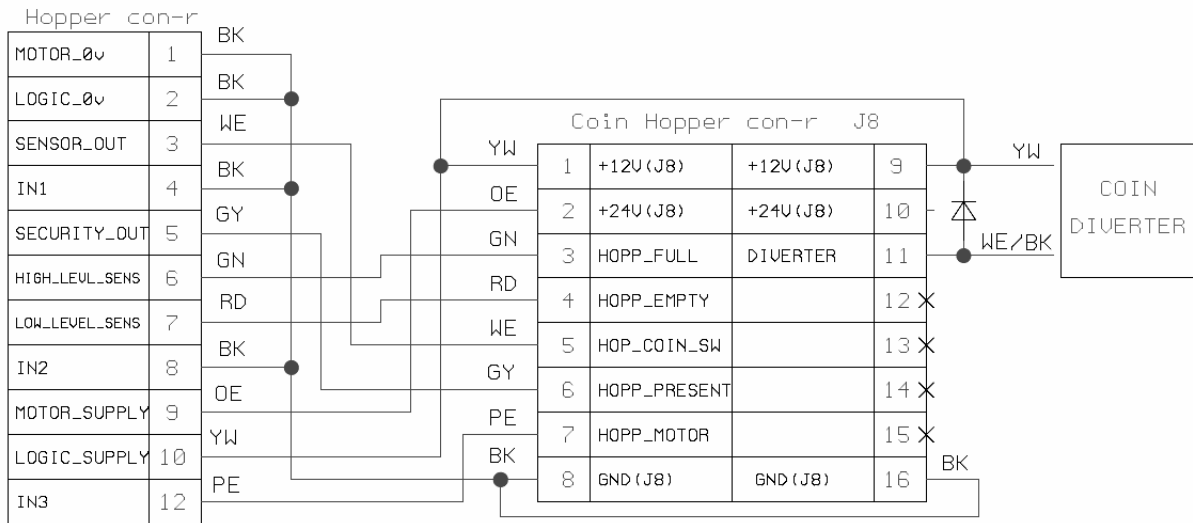

Figure 22: Coin Hopper Connector

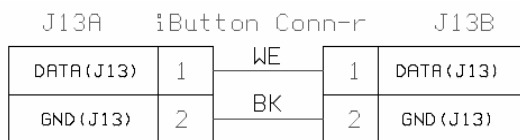

Figure 23: iButton Connector

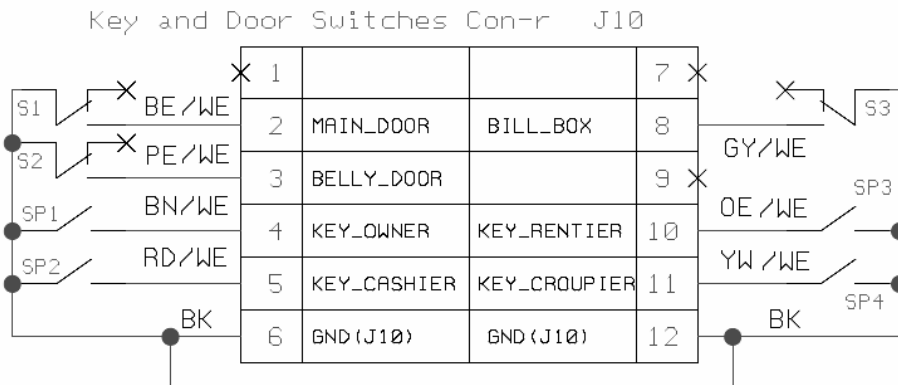

Figure 24: Key and Door Switch Connector

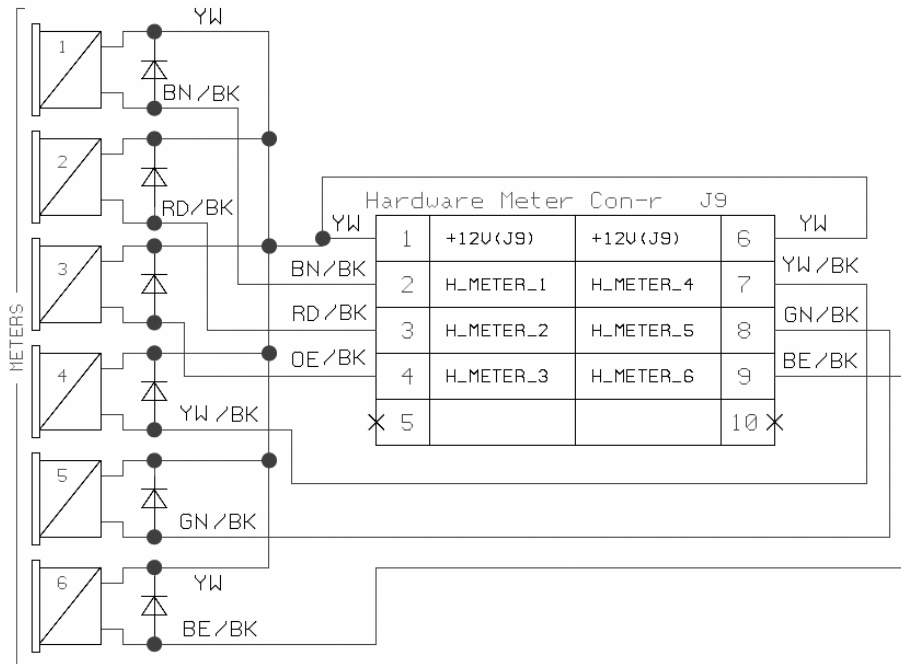

Figure 25: Hardware Meters Connector

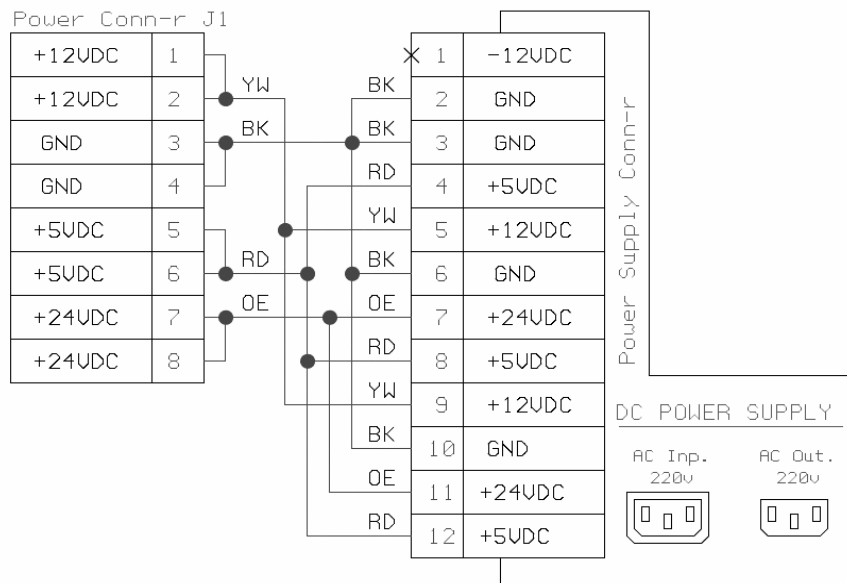

Figure 26: Power Connector

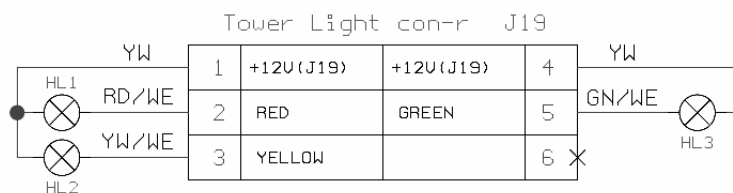

Figure 27: Tower Light Connector